

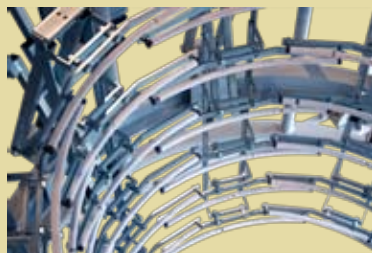

ADDEX[®]

SCC Scissor Calibration Cage

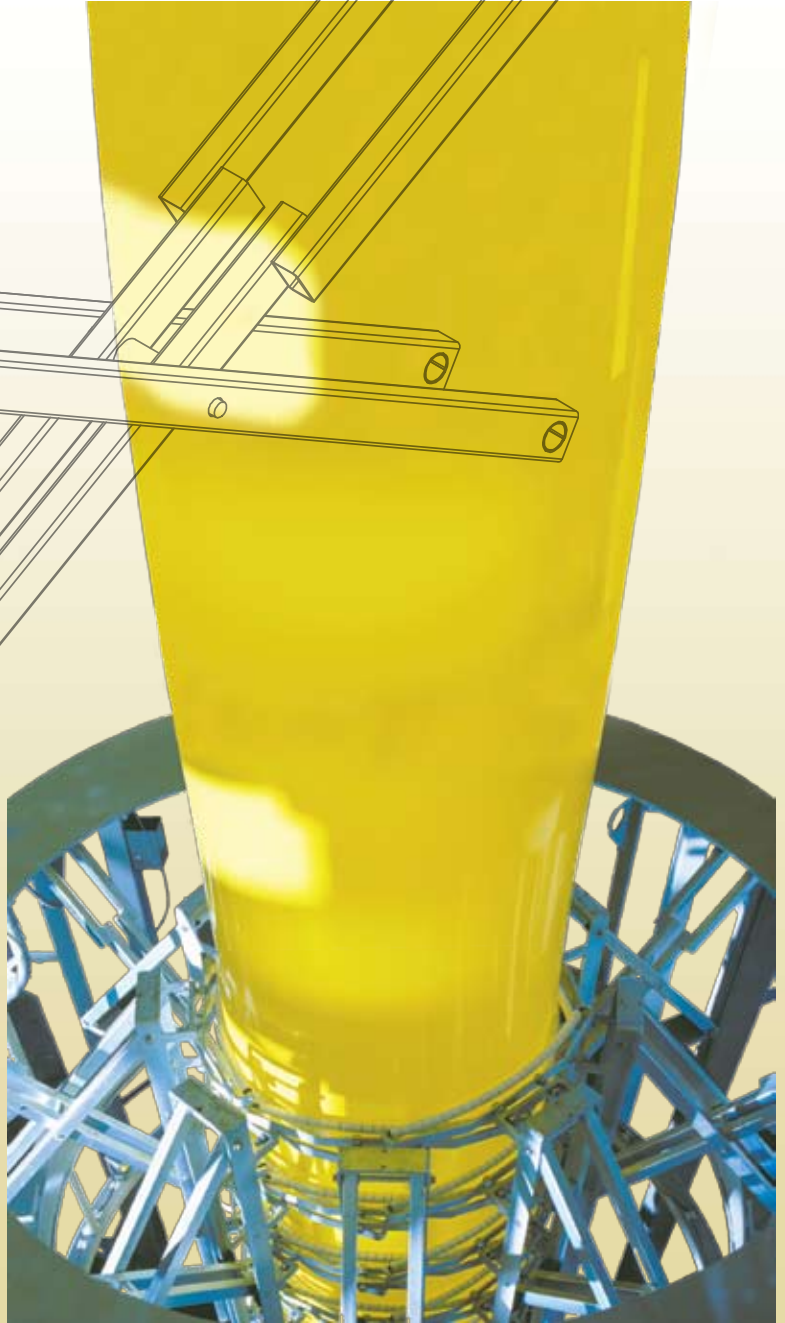
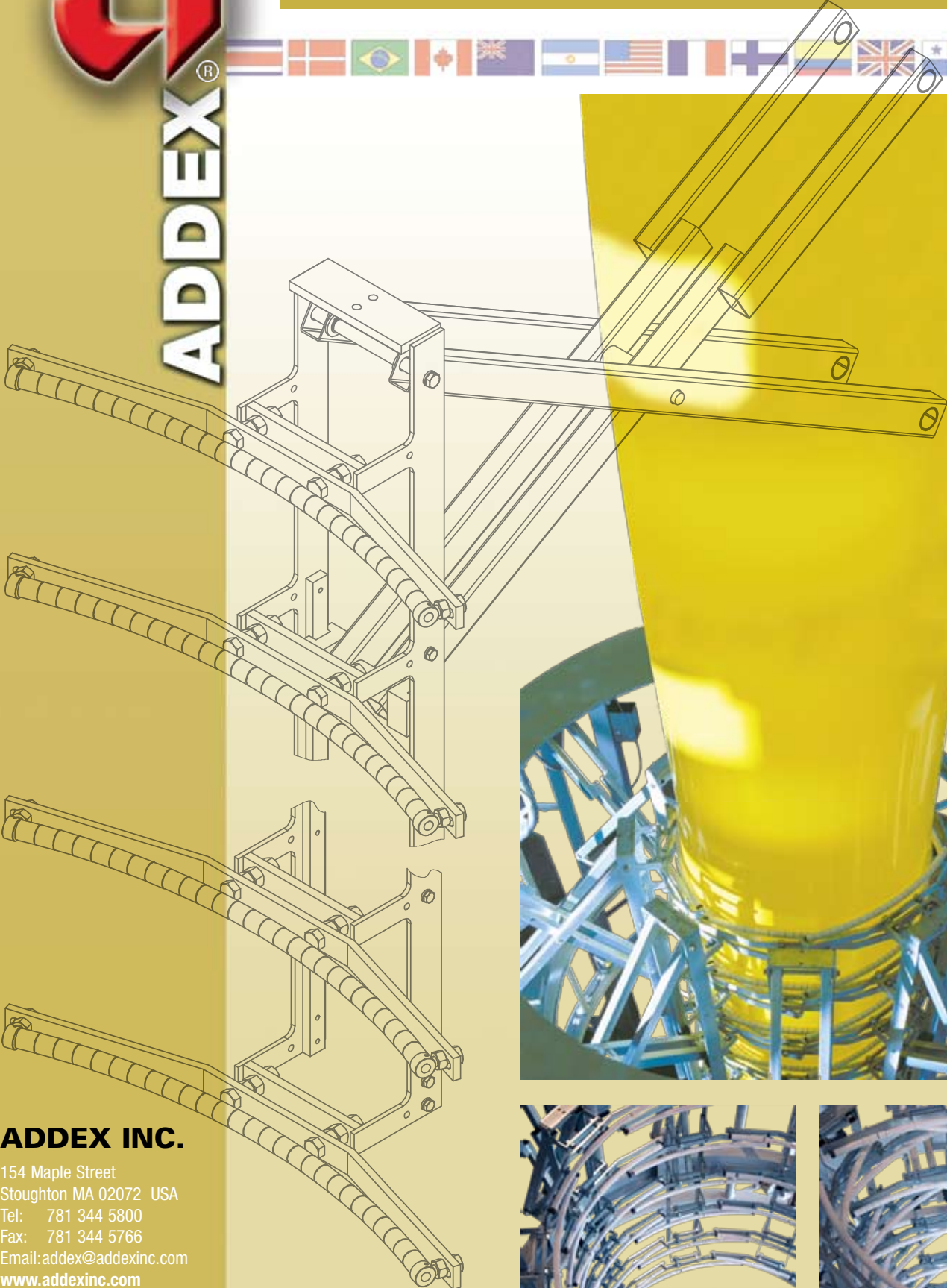

ADDEX INC.

154 Maple Street
Stoughton MA 02072 USA
Tel: 781 344 5800
Fax: 781 344 5766
Email: addex@addexinc.com
www.addexinc.com

SCC Scissor Calibration Cage

TYPE	LF (mm)	d (mm)	D (mm)	A (mm)	B (mm)	E (mm)	F (mm)	Weight (kg)
SCC 130/9-6	460-1300	295	870	1860	1690	404	707	780
SCC 160/9-6	570-1600	360	1070	1860	1690	404	707	800
SCC 200/9-6	670-2000	425	1340	2170	2000	500	866	900
SCC 240/9-6	805-2400	510	1610	2430	2260	565	979	1000
SCC 280/9-6	930-2800	590	1880	2730	2560	640	1109	1100

TYPE	LF (inches)	d (inches)	D (inches)	A (inches)	B (inches)	B (inches)	B (inches)	B (lbs)
SCC 130/9-6	18.0-51.0	12.0	34.0	73.0	66.5	16.0	28.0	1700
SCC 160/9-6	22.5-65.0	14.0	42.0	73.0	66.5	16.0	28.0	1760
SCC 200/9-6	26.5-79.0	17.0	52.0	85.0	79.0	20.0	34.0	1980
SCC 240/9-6	31.5-94.5	20.0	63.5	95.5	89.0	22.0	38.5	2200
SCC 280/9-6	36.5-110	23.0	74.0	107.5	101.0	25.0	43.5	2420

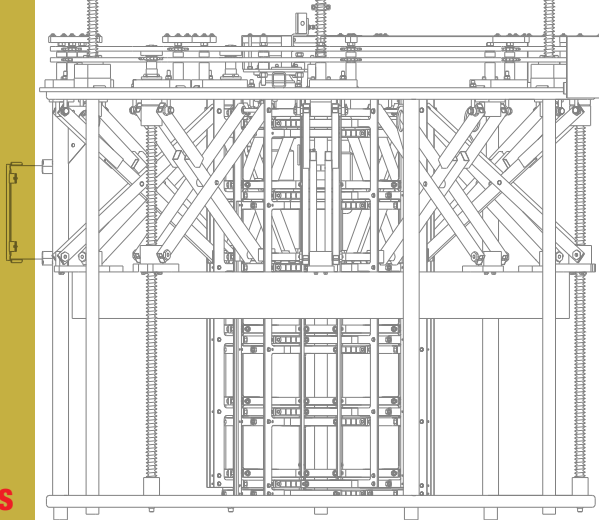

COMPONENTS AND FEATURES

- A rigid tubular frame.
- 6 levels, each made up of 9 arms that overlap in order to encompass each bubble diameter within the range of the cage.
- All the arms are shaped and beaded with low friction Teflon rollers.
- The scissor action mechanism assures a perpendicular movement of the arms to the bubble.
- The opening or closing of the cage is accomplished via motor driven spindles.
- The 67"/1700 mm height adjustment is accomplished via nuts driven up and down a set of fixed spindles.
- The scissor mechanism and arms are zinc-chromated to prevent corrosion.

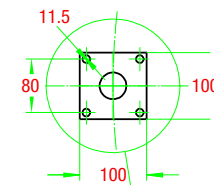
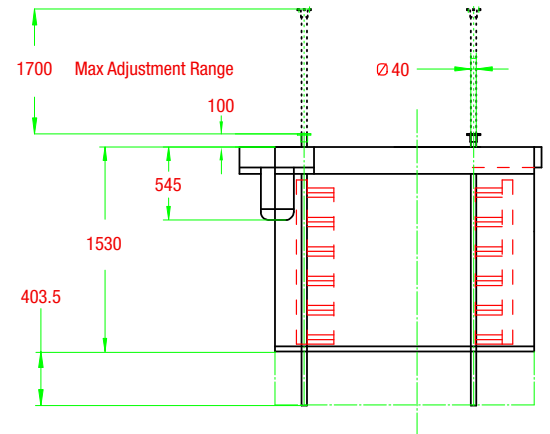

Precise dimensions are in mm.
US measures are rounded.
ADDEX reserves the right
to technical changes.

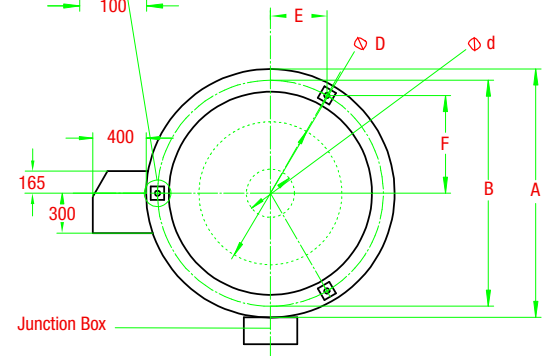

OPTIONS

- Control panel with push buttons for the in/out and the up/down movements.
- Mounting frame made out of a square frame with steel brackets. Second frame with U beams (to be mounted on the tower platform) equipped with adjustment screws for the centering of the cage.
- One piece Teflon rollers in lieu of segmented ones.
- Additional height adjustment.



OTHER ADDEX PRODUCTS

- Automatic Gauge Controls
- Air Rings
- Oscillating Haul-offs
- Dies
- Extruders
- Winders (Surface/Center)
- Complete Blown Film Lines



ADDEX INC.

154 Maple Street
Stoughton MA 02072 USA
Tel: 781 344 5800
Fax: 781 344 5766
Email: addex@addexinc.com
www.addexinc.com